

*Give the best back to earth*

**A 15 YEAR GUARANTEED  
TANK AGAINST CORROSION**

**6030**  
2014/12/12

## TECHNICAL DEFINITION

The BIOXYMOP water-treatment plants are based on the principle of aerobic immersed fixed culture. The Bioxymop plants treat domestic wastewater coming from individual dwellings. Designed to be easily installed, this sanitation solution guarantees one of the most efficient treatment (CE marking).

## OPERATION

The plants BIOXYMOP consist of 3 compartments :

- Primary decanter
- Aeration basin
- Clarifier

Domestic wastewater come into the primary decanter where larger particles and floatings are retained. Then the effluent passes through the aeration tank where dissolved pollutants are removed by purifying bacteria attached to the free supports.

The final stage of the treatment occurs in the clarifier. The treated effluent is separated from suspended solids.

The treated effluent meets the applicable standards.

Discharges of treated wastewater can be done in two ways :

- by drainage and infiltration into the soil
- by discharge to mid-water surface, subject to compliance with the applicable technical requirements.

## INSTALLATION

Refer to data sheet P070 and P071.

The compressor must be necessarily installed outside of the residential water treatment plant in the outside box.

The air pipe linked the compressor with the cleaning plant must be move up in the sheath. In the standard cases, the cleaning plant is delivered with 10m of air pipe.



## ADVANTAGES

- Very low energy consumption
- Very small footprint
- Low maintenance cost
- Low digging depth (2m)
- Frequency of drainings spaced
- Installation on ground with or without a water table
- Primary decanter with a large volume
- Easy handling
- Good tolerance to load variations
- Easy maintenance

## MAINTENANCE

All maintenance instructions are in the maintenance book.

## GUARANTEE

From the commissioning, a maintenance contract has to be take out with a specialized company accredited by SIMOP.

THE RESULTS OF THE GUARANTEE, THE OPERATION AND ELECTROMECHANICAL PARTS CAN ONLY BE ACQUIRED ON THIS CONDITION.

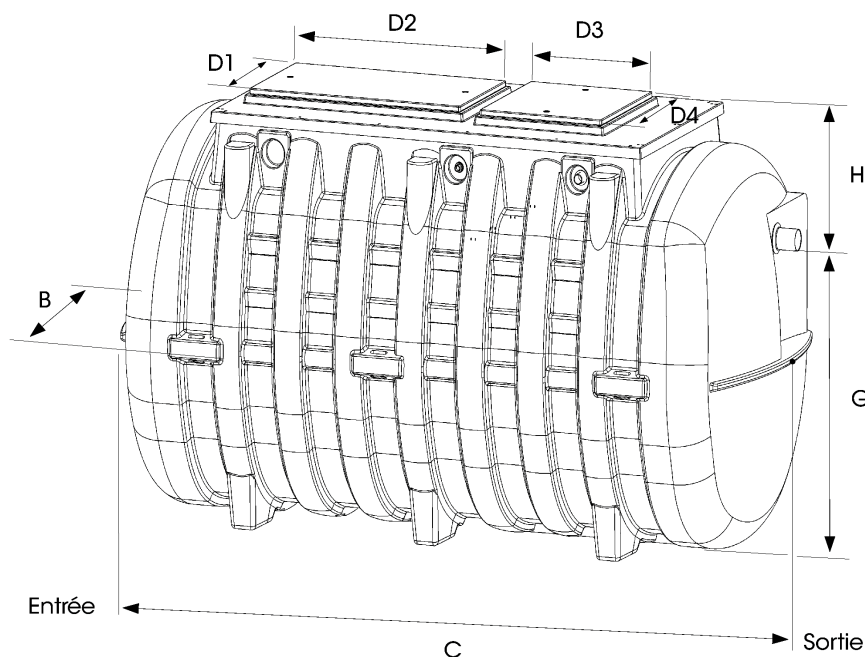
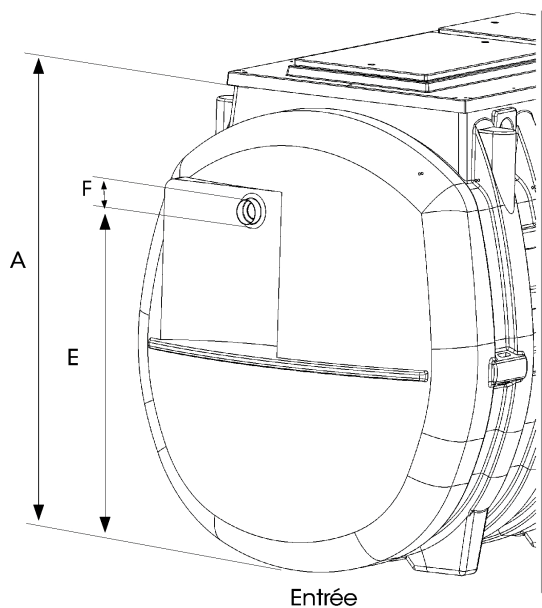

Reference	PE	Frame (nbr)	A	B	C	D1/D2	D3/D4	E	F	G	H	Weight (kg)
BIOXYMOP6030/09	9	1	2105	1946	2829	1130/570	-	1430	100	1380	725	560
BIOXYMOP6030/12	12	2	2105	1946	3954	1130/570	672/580	1480	100	1430	675	755