



20 YEAR  
WARRANTY  
AGAINST  
CORROSION



### Installation

(see installation instructions P046)

Small communities, industrial facilities, collective kitchens, restaurants, ... have to be equipped with a grease separator according to the code of public health and the inter-communal or sanitation regulations.

Food industries have to send us the STS (Special Technical Specifications) in order to calculate the appropriate size of the device.

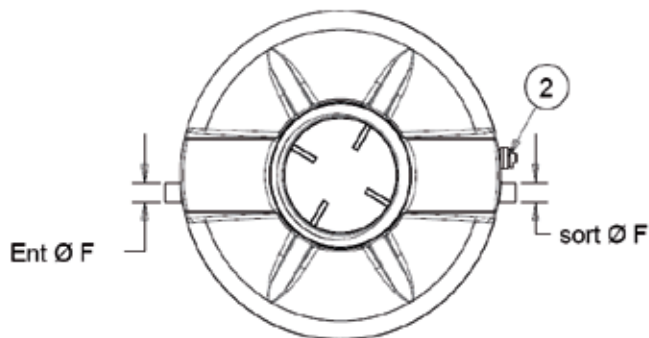
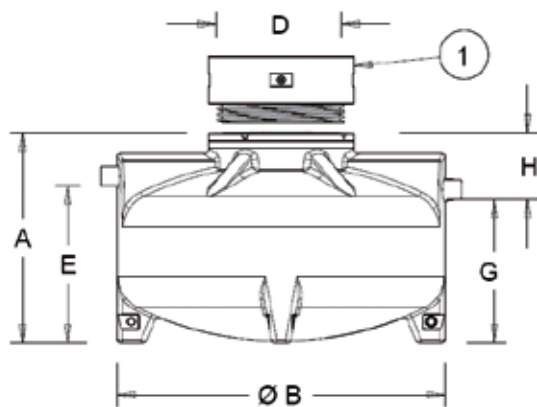

1 -Screw-on estension shafts height 250 mm (Ref. RH602). *Option*

2 -Extraction device (Ref. ND 80). *Option*

Grease level alarm, see page 28. *Option*

Reference	Size	A	ø B	ø D	E	ø F	G	H	Silt storage Volume	Separator Volume	Extraction Device
SG2/6630/01	1	765	1244	600	485	100	415	350	103	262	OD4-BBTN1
SG2/6630/02	2	1059	1244	600	779	100	709	350	205	509	OD4-BBTN2
SG2/6630/03	3	1356	1244	600	1076	100	1006	350	306	756	OD4-BBTN3
SG2/6630/04	4	1100	1720	600	825	100	755	345	416	982	OD4-BBTN4
SG2/6630/05	5	1330	1720	600	975	160	905	425	526	1228	OD4-BBTN5
SG2/6630/06	6	1475	1720	600	1120	160	1050	425	612	1468	OD4-BBTN6
SG2/6630/07	7	1635	1720	600	1280	160	1210	425	722	1720	OD4-BBTN7