

## SILT STORAGE APOLLO RANGE

INSTALLATION ON GROUND WITH WATER TABLE AND/OR INSTALLATION WITHOUT CONCRETE SLAB / EMBANKMENT HEIGHT UP TO 800 MM IN POLYETHYLENE

6603



20 YEAR WARRANTY AGAINST CORROSION

### Installation

(see installation instructions P046)

Upstream from pre-treatment facilities to retain heavy matter contained in waste water.

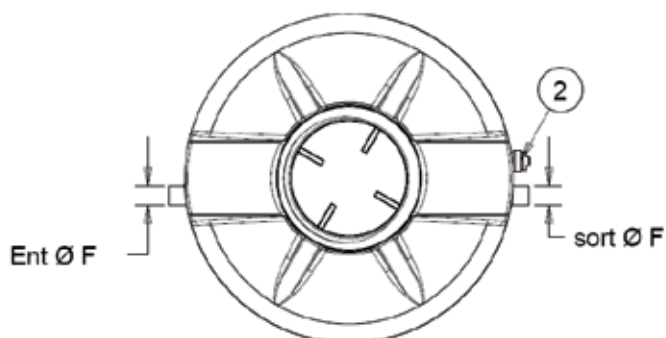
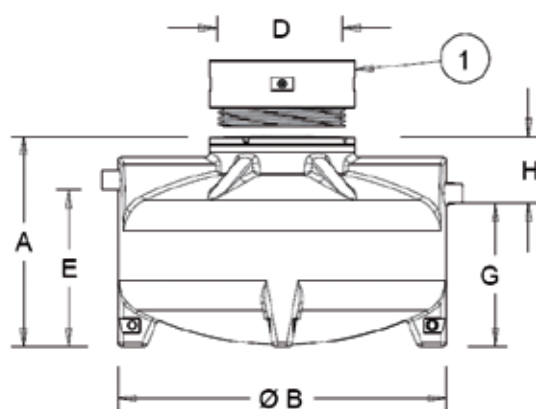

- 1 - Screw-on extension shaft height 250 (Ref. RH602). *Option*
- 2 - Extraction device (Ref. ND80). *Option*

Reference	Size	A	Ø B	Ø D	E	Ø F	G	H	Silt storage Volume	Extraction Device
DB2/6603/0340	3	765	1244	600	485	100	415	350	368	OD4-BBTN1
DB2/6603/0341	6	1059	1244	600	704	160	634	425	633	OD4-BBTN2
DB2/6603/0342	9	1356	1244	600	1001	160	931	425	983	OD4-BBTN3
DB2/6603/1200	12	1100	1720	600	731	200	661	439	1200	OD4-BBTN4
DB2/6603/1700	17	1330	1720	600	931	200	861	439	1725	OD4-BBTN5
DB2/6603/2000	20	1475	1720	600	1106	200	1036	439	2054	OD4-BBTN6
DB2/6603/2400	24	1635	1720	600	1266	200	1196	439	2416	OD4-BBTN7

Options :  
Screw-on extension shaft in polyethylene height 250 mm (Ref. RH602).  
Sludge level alarm (Ref. ANB2).