

RAINWATER HARVESTING TANK

AQUAMOP 10 TO 20 M3 UNDERGROUND

POLYETHYLENE (PE)

SIMOP
EQUIPEMENTS POUR L'ENVIRONNEMENT

Redonnons le meilleur à la terre

6328

1 Technical definition

The collected water flows into the tank, first passing through a downspout filter and then arriving in the tank filter, which has a filtration fineness of less than 1 mm.

An anti-settling device prevents the heaviest fine matter from being resuspended after settling. When the tank is full, excess water is returned to the collection network or to an overflow.

Aquamop complies with the design rules set out in standard NF P 16-005, which also specifies the rules for sizing, installation, commissioning, maintenance and servicing. Tank made of linear medium-density polyethylene



2 Maintenance

- Cleaning the grid and filter in the collection system (2 times a year).
- Check the condition of the suction strainer by lifting the collection system (clean twice a year).
- For annual maintenance, it will be necessary to drain and clean the walls.

4 Guarantee

Warranty The vat room is covered by a 10-year anti-corrosion warranty.

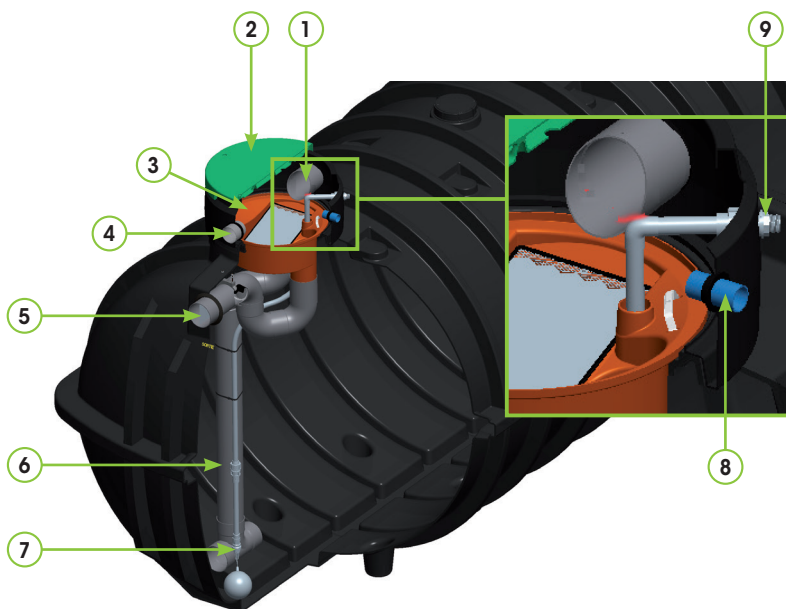

1. Rainwater inlet $\varnothing 160$
2. Lockable lid
3. Collector system with filter handles
4. Ventilation DN100 PVC
5. $\varnothing 160$ overflow equipped with check valve
6. Suction tube with strainer and float
7. Anti-burrow dip tube
8. Submersible pump cable outlet DN50
9. 1" threaded wall feed-through for connection of a surface pump or manager (see options)

RAINWATER HARVESTING TANK

AQUAMOP 10 TO 20 M3 UNDERGROUND

POLYETHYLENE (PE)

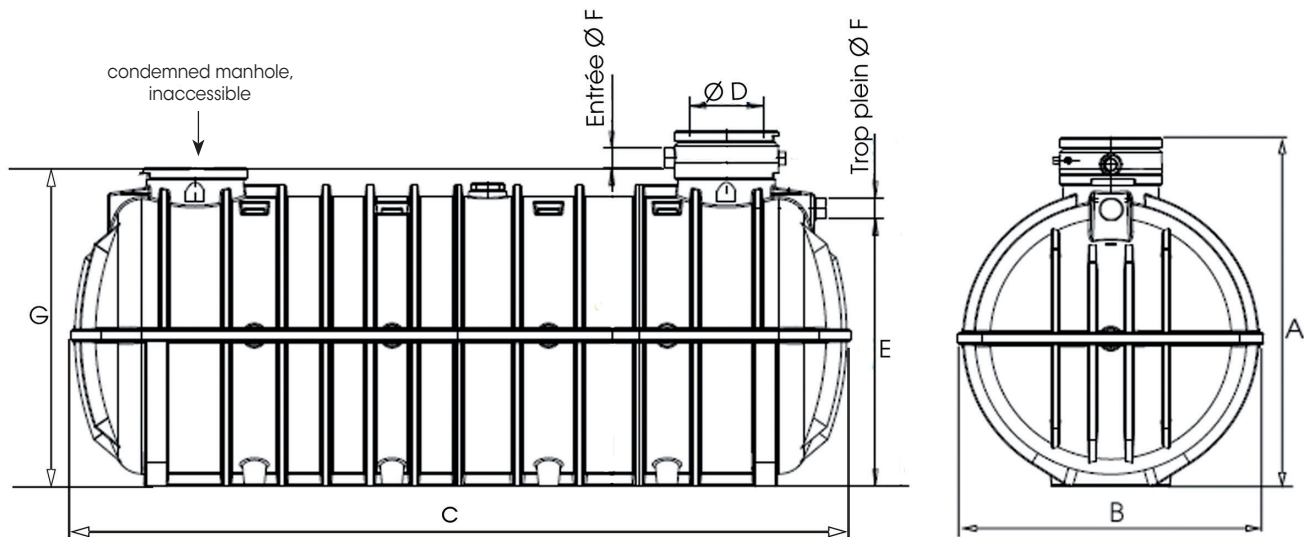

| Reference | Volume | A | ø B | C | ø D | E | ø F | G | No. of belts (optional) |
|--------------|----------|------|------|------|-----|------|-----|------|-------------------------|
| CEP2/6328/10 | 10 000 L | 2840 | 2490 | 3378 | 600 | 2140 | 160 | 2540 | 3 |
| CEP2/6328/12 | 12 000 L | 2840 | 2490 | 3928 | 600 | 2140 | 160 | 2540 | 4 |
| CEP2/6328/15 | 15 000 L | 2840 | 2490 | 4782 | 600 | 2140 | 160 | 2540 | 4 |
| CEP2/6328/20 | 20 000 L | 2840 | 2490 | 6232 | 600 | 2140 | 160 | 2540 | 4 |

5 Optional equipment

Provide a pumping or management system adapted to the volume of the tank and its intended use.

Consult our technical advisors for more information.

| Options | |
|--------------|---------------------------------------|
| CA3/6394/10T | Anchoring belt 10T 10M |
| RH2/6030 | Polyethylene extension, 300 mm high |
| FDG12 | Simplified downspout filter |
| FGU11 | UV filtration system |
| PP58/06 | Surface pumping kit. See FT 6032 |
| PP58/11 | Pumping kit with manager. See FT 6032 |
| PP58/14 | AC500 Manager. See FT 6033 |

RAINWATER HARVESTING TANK

AQUAMOP 10 TO 20 M3 UNDERGROUND

POLYETHYLENE (PE)

INSTALLATION

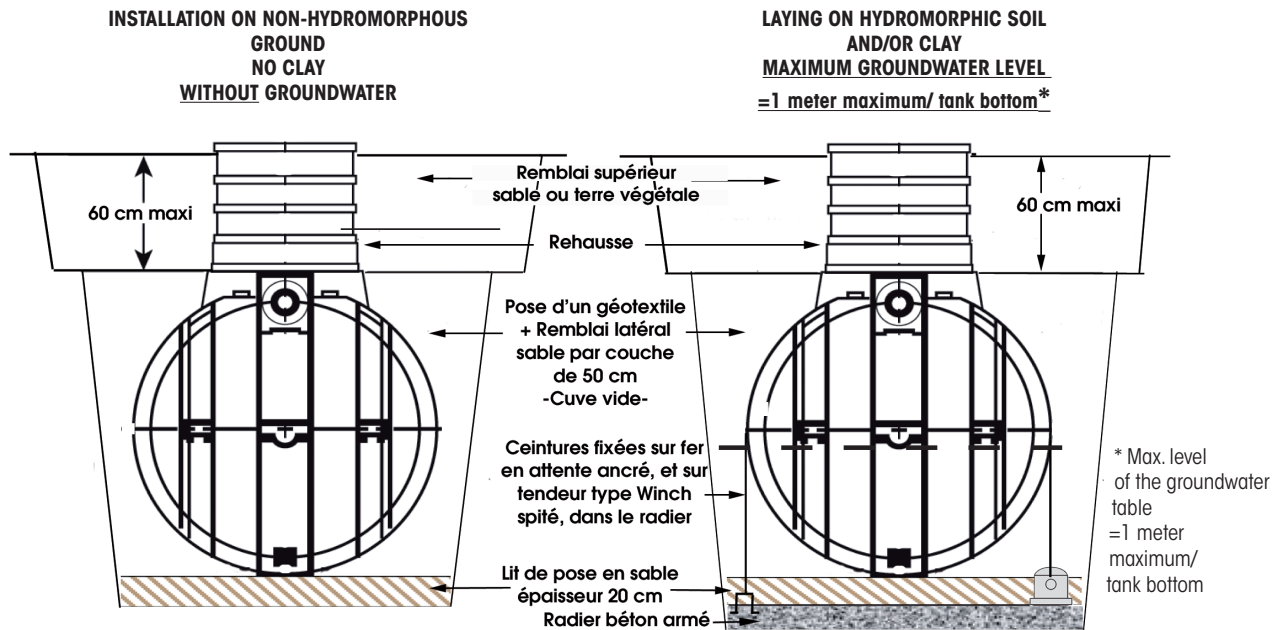

• **Handling** : Tanks must be handled using chain slings to be attached to the lifting rings, and with lifting equipment suited to the volume of the tank.

Chain slings must be provided by the installing company.

Provide access to means of transport adapted to the location.

• **Earthworks** : The height of the tank must be calculated in such a way that the height of the groundwater table does not exceed 1 meter above the bottom of the tank.

Create a separate excavation for each tank and, if necessary, draw down the groundwater table until backfilling of the unit is complete.

The walls of the excavation should be approximately 50 cm around the tank.

The bottom of the embankment constituting an earthen merlon must be at least 4 m around the tank.

• **Creation of a heavily reinforced concrete protection slab in the following cases** :

1. In case of backfill more than 60 cm above the upper generatrix of the tank.

2. In case of punctual overload due to the passage of vehicles at less than 4 m from the edge of the excavation.

3. When using concrete sockets.

4. In case of overloads due to extreme weather conditions. This slab must be supported on stabilized, undisturbed ground all around the excavation.

Caution: After backfilling with sand, fill the tank to overflowing level before pouring the reinforced concrete protection slab.

• **Anchoring belts** : Use suitable polyester belts, which must not be overstretched to avoid tank ovalization.