

GREASE SEPARATORS
REMOTE EXTRACTION SYSTEM OPTION

OPTION

The separator is equipped with a DN80 extraction device

Grease separator in the courtyard behind the restaurant. Not accessible to draining truck

Option dN80 extraction device

Fireman's connection supplied with separator, installed at street level

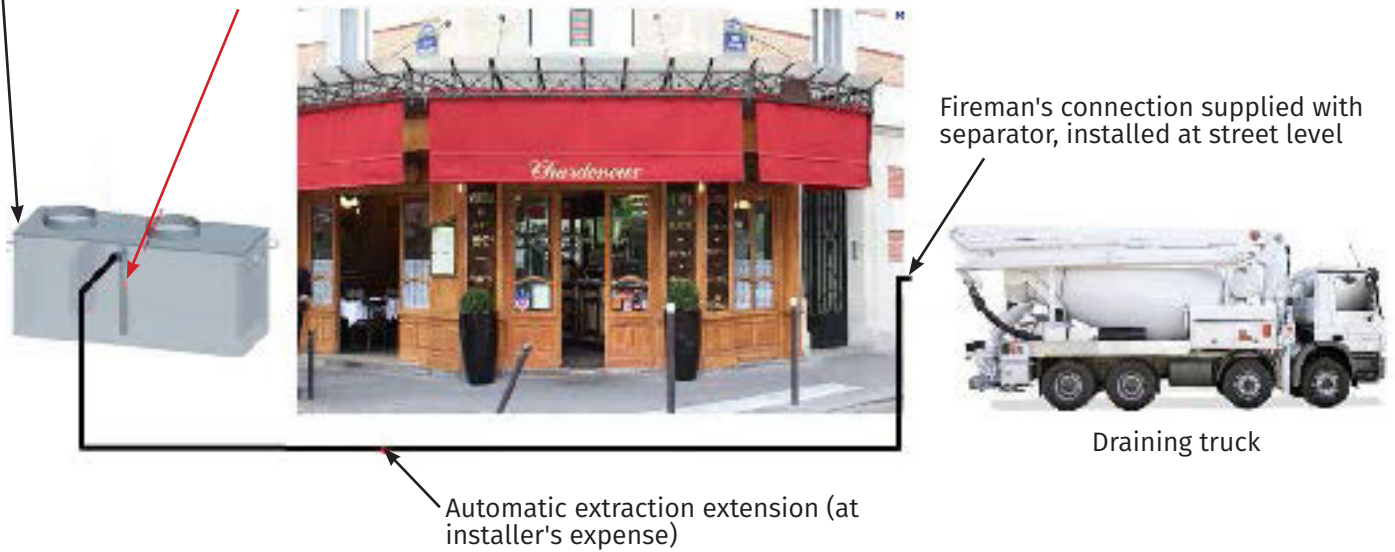

WASTEWATER TREATMENT

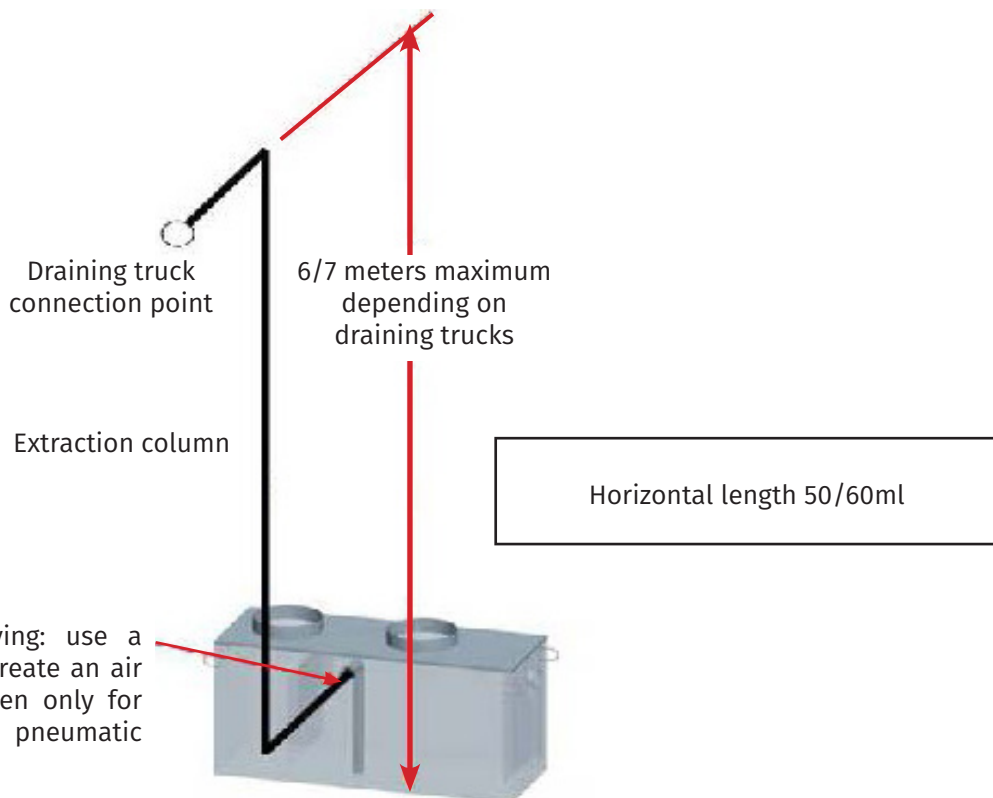

Tip to improve emptying: use a spigot with a valve to create an air intake (the valve is open only for emptying, to achieve pneumatic extraction)

GREASE SEPARATORS

REMOTE EXTRACTION SYSTEM OPTION

OPTION

Example of an APOLLO grease separator

