

## GREASE AND STARCH SEPARATORS SEPARATORS

### APOLLO SLUDGE TRAP V100 RANGE - SIZES 1 TO 7

IN-GROUND OR ABOVE-GROUND INSTALLATION

MAXIMUM BACKFILL HEIGHT OF 800 MM

POLYETHYLENE (PE)

6634

GARANTIE  
CONTRE LA  
CORROSION  
JUSQU'À

20 ANS

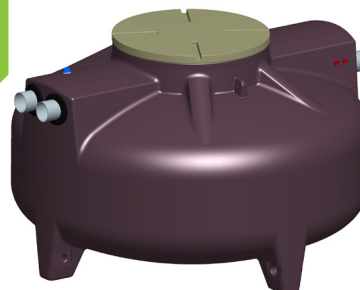

#### 1 Technical definition

A combined grease and starch separator is a device designed to separate and store solid matter, fats and oils of animal and vegetable origin contained in household wastewater, and to retain peeling waste.

A starch foam spray system is installed above the effluent inlet from the potato peeler. The spray system must be controlled by the peeler.

A V100 silt storage zone is integrated in each unit.

Our devices comply with standard NF EN 1825-1 and are CE marked.

Grease retention capacity is 40 liters per l/s.

#### 2 Use

**Concerning small communities and professional installations, collective kitchens, restaurants** the obligation to install grease separators is based on the standard departmental sanitary regulations and the public health code. **For the food-processing industries** for food industries, it is essential to transmit the CCTP of a technical research department to establish the dimensioning of an adapted device.

#### 3 Installation

The unit is to be installed underground, in the presence of groundwater or in hydromorphic soil whose level does not exceed the upper generatrix of the unit.

Where vehicles pass over the separator, or where the height of the backfill above the separator exceeds 800 mm, a reinforced concrete slab should be poured, supported on the undisturbed ground, so that the separator is not directly subjected to the loads.

**This device can also be installed in elevation:**

It must be installed level on a perfectly flat and smooth surface all around the unit. The cover must always remain accessible for maintenance.



**IMPORTANT** please refer to our website to consult the current documents **installation instructions P046**. For above-ground installation, the room must be equipped with a water collection and drainage system to prevent flooding in the event of overflow

#### 4 Maintenance

The cleaning company must empty the unit regularly, from 15 days to 2 months, depending on the amount of solids and grease collected.



**IMPORTANT** after each complete draining, wash the unit and fill it immediately with clean water.

#### 5 Remote extraction

Remote extraction in DN80 is possible by ordering **option OD4/BBTN... (1 to 7 depending on size)**. The installer must supply and install a PVC pressure suction pipe to be connected to the unit outlet, and must fit the fireman's fitting supplied with the option at the curb.

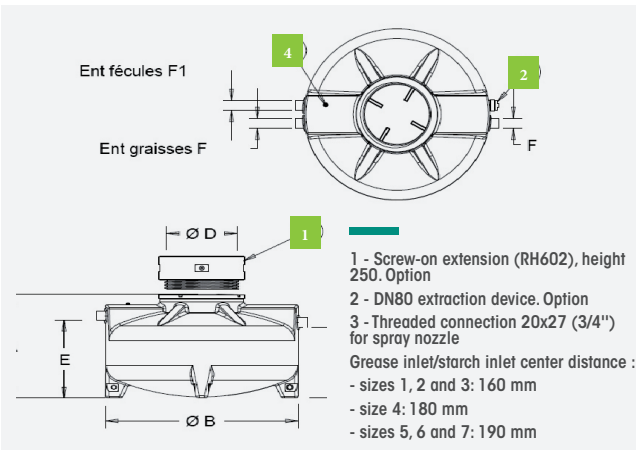

Reference	Size	A	Ø B	Ø D	E	Ø F	Ø F1	G	H	Volume Sludge trap (l)	Volume Separator (l)	Extraction device option
SG2/6634/01	1	765	1244	600	485	100	100	415	350	100	260	OD4-BBTN1
SG2/6634/02	2	1059	1244	600	779	100	100	709	350	200	505	OD4-BBTN2
SG2/6634/03	3	1356	1244	600	1076	100	100	1006	350	300	755	OD4-BBTN3
SG2/6634/04	4	1100	1720	600	825	100	100	755	345	400	980	OD4-BBTN4
SG2/6634/05	5	1330	1720	600	975	160	100	905	425	500	1225	OD4-BBTN5
SG2/6634/06	6	1475	1720	600	1120	160	100	1050	425	600	1468	OD4-BBTN6
SG2/6634/07	7	1635	1720	600	1280	160	100	1210	425	700	1720	OD4-BBTN7

#### Options :

RH602..... Polyethylene extension to screw on, height 250 mm  
ANG2-3..... Level alarm for grease traps  
ANG2-3-N..... Simplified level alarm for grease traps (1 probe possible)  
SNB/SG..... Sludge probe