

# STARCH SEPARATORS

## APOLLO RANGE, SIZE 1 TO 5

BURIED INSTALLATION (WITHOUT WATER TABLE)  
MAXIMUM BACKFILL HEIGHT OF 400 MM  
POLYETHYLENE (PE)

**6626**

### 1 Technical definition

A starch separator is a device designed to break down foam and store any solids.

A starch foam spray system is installed above the effluent inlet from the potato peeler.

The spray system must be controlled by the peeler.

### 2 Use

For small communities and professional facilities such as kitchens and restaurants the obligation to install grease separators stems from the standard departmental sanitary regulations and the public health code.

**IMPORTANT** : For units to be buried in groundwater or hydromorphic soil, select a unit from data sheet 6636.

### 3 Maintenance

The cleaning company must empty the unit regularly, from 15 days to 2 months, depending on the amount of solids and grease collected.

**IMPORTANT** after each complete draining, wash the unit and fill it immediately with clean water.

### 4 Installation

The device must be buried outside groundwater or hydromorphous soil, or it can be installed above ground.

#### Buried installation :

In case of vehicle traffic or rolling loads or if the height of the backfill is higher than 400 mm above the device, a reinforced concrete slab must be poured, supported on the undisturbed ground, so that the separator is not directly subjected to the loads.

**IMPORTANT** : Please refer to our website to consult the current documents, especially the installation instructions P045.

GARANTIE  
CONTRE LA  
CORROSION  
JUSQU'À  
**20 ANS**

CE  
EN 1825-1

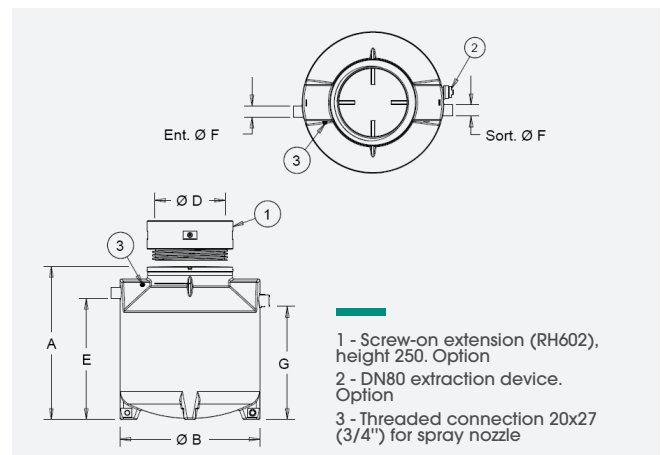

### 5 Remote extraction

Remote extraction DN80 is possible by ordering option **OD4-BBTN 1 to 5** (depending on size). The installer must supply and install a PVC pressure suction pipe to be connected to the unit outlet, and must place the fireman's connector supplied with the option at the curb.

Reference	Size	A	Ø B	Ø D	E	Ø F	G	H	Volume of sludge trap (l)	Volume Separator (l)	Extraction device option
SF2/6626/01	1	765	1244	600	485	100	415	350	103	262	OD4-BBTN1
SF2/6626/02	2	1059	1244	600	779	100	709	350	205	509	OD4-BBTN2
SF2/6626/03	3	1356	1244	600	1076	100	1006	350	306	756	OD4-BBTN3
SF2/6626/04	4	1100	1720	600	825	100	755	345	416	982	OD4-BBTN4
SF2/6626/05	5	1330	1720	600	975	160	905	425	526	1228	OD4-BBTN5
SF2/6626/06	6	1475	1720	600	1120	160	1050	425	612	1468	OD4-BBTN6
SF2/6626/07	7	1635	1720	600	1280	160	1210	425	722	1720	OD4-BBTN7

#### Options :

RH602 .....Polyethylene extension to screw on, height 250 mm