

SEPTIC TANK FOR BLACK WATER

1000 & 2000 L

POLYETHYLENE (PE)

6015

1 Technical definition

A septic tank is a pre-treatment device designed to retain the settleable matter present in the black water (W.C.) from residential houses.

The interministerial decree of 06 May 1996 allows for separate treatment of black water and grey water subject to a favourable opinion from the D.D.A.S.S. of the place where this type of tank is installed.

When authorised, the volume of septic tank must be at least equal to half the minimum volumes retained for all-water septic tanks.

2 Operation

The wastewater are collected in the all-water tank. The suspended solids settle and ferment.

Over the time, this volume decreases and stabilises. On the surface, the fats are trapped, hydrolyse and form the "cap".



IMPORTANT : The larger an all-water tank is, the more space there is for sludge, the more efficient the digestion.

3 Installation

The device will be buried outside of the building. In general, refer to the experimental standard XPP 16-603 concerning the implementation of independant sanitation system.

The cover should be level with the floor. The bottom of the excavation must be perfectly flat and covered with at least of 10 cm of sand. Position the device and adjust the pipe levels.

Fill the unit with water then backfill the perimeter with washed sand up to the upper generator of the device. If the manhole needs to be raised, use only polyethylene extension shafts.

INSTALLATION WITHOUT PROTECTIVE SLAB

If the inlet/finished ground level is less than 50 cm, the backfill above the device can be made with sand.

INSTALLATION WITH PROTECTIVE SLAB

If the height of the water line/finished ground is greater than 50 cm or if vehicles pass within 3 meters, a reinforced concrete protection slab must be built just above the upper generator of the device.

This slab must rest on the stabilised and undisturbed ground and must be capable of supporting the loads. When the protective slab is dry, finish backfilling with the material of your choice.



Guarantee against corrosion
20 YEARS

WASTEWATER TREATMENT

4 Ventilation

Connect the ventilation ND 100 according to the experimental standard XPP 16-603.

5 Maintenance

Polyethylene tanks are insensitive to corrosion and do not require any particular maintenance. According to the ministerial decree of 07/09/09, it is necessary to carry out an emptying when the volume of sludge reaches 50% of the volume of water in the tank.

Do not empty the equipment during periods of heavy rainfall. The prefilter must be cleaned with a water jet, removing it if necessary.

6 Conseils

To reduce the proliferation of mosquitoes in the system, the effluent should not be accessible from the outside, so:

- close all covers tightly,
- check and clean regularly the anti-mosquito screens on the air intake cap,
- ensure that the secondary ventilation outlet is equipped with an anti-mosquito screen or an anti-odour filter.

Reference	Sizes in mm							Weight (kg)	Use volume (L)
	A	Ø B	Ø D (int)	E	Ø F	G	H		
FSD 1000	1434	1160	400	1090	100	1133	300	40	1000
FSD 2000	1594	1550	400	1203	100	1253	340	70	2000
RH2/4031	Re-cutting scrow-on extension shaft, height 300mm								

SEPTIC TANK FOR BLACK WATER

1000 & 2000 L
POLYETHYLENE (PE)

6015

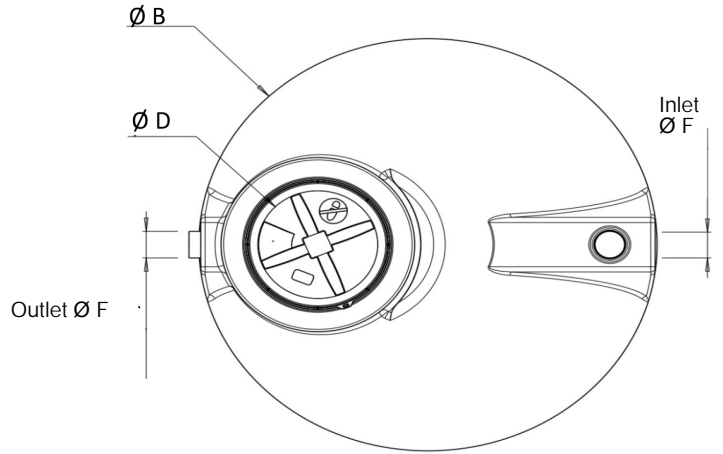
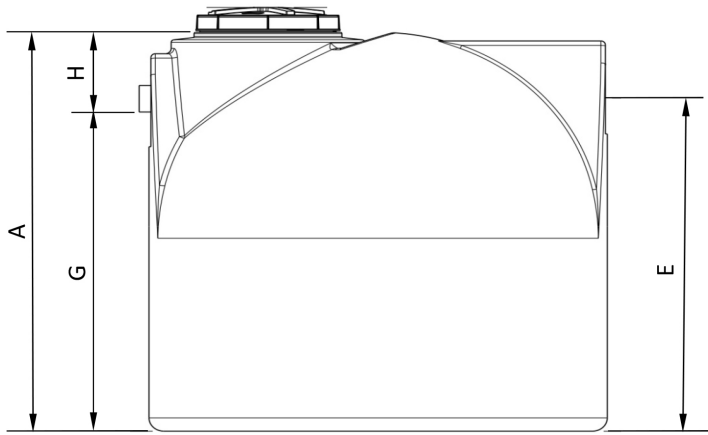

WASTEWATER TREATMENT

INSTALLATION INSTRUCTIONS WITHOUT PROTECTIVE SLAB

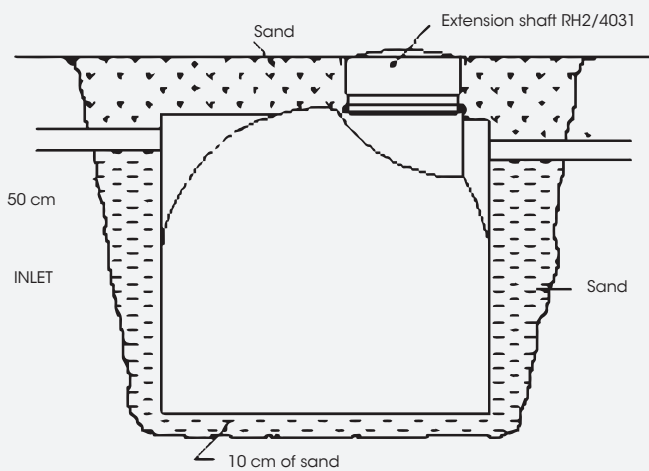

INSTALLATION INSTRUCTIONS WITH PROTECTIVE SLAB

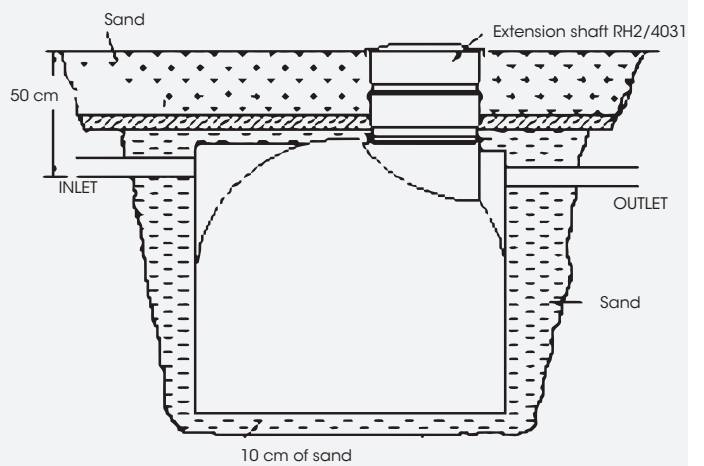

If the waterline / finished ground level is greater than 500 mm or in case when vehicles pass within 3 m