

ALL WATER PITS FROM 10 TO 12 M³ POLYETHYLENE (PE) LAYING ON THE GROUND

6309

1 Technical definition

All-water tank in polyethylene, monobloc **with incorporated prefilter**, intended to retain the decantable matters present in the domestic wastewater. Domestic wastewater is black water (w.c....) and grey water (bathroom, kitchen, laundry).

A complete wastewater treatment system consists of an all-water tank and a secondary treatment system, either through the soil or via another filter bed.

2 Functioning

The wastewater is collected in the all-water tank. The suspended solids settle and are digested. Over time, the volume of sludge decreases and stabilizes. On the surface, the grease is trapped and slowly hydrolyzes.

3 Maintenance

Polyethylene pits are not susceptible to corrosion and do not require special maintenance. It is necessary to empty the tank when the volume of sludge reaches 50% of the volume of water in the tank.

Before emptying, make sure that the water level in the piezometer is not higher than 1 m. If this is not the case, it is necessary to postpone the draining or to lower the water table.

Avoid emptying during rainy periods and after each emptying, it is imperative to immediately fill the pit with clear water until it overflows through the outlet pipe.

The integrated pre-filters are cleaned with a water jet, removing them if necessary.

4 Sizing

The capacities of the SIMOP all-water pits take into account 2 criteria:

- Sludge storage volume
- the admissible flow rate

These criteria have enabled SIMOP to characterize the type of tank adapted to the need according to the permanent or non-permanent use of the grouped habitat. On the basis of 150 liters of water consumed per day and per inhabitant, our all-water pits can be used according to table 01.



CE

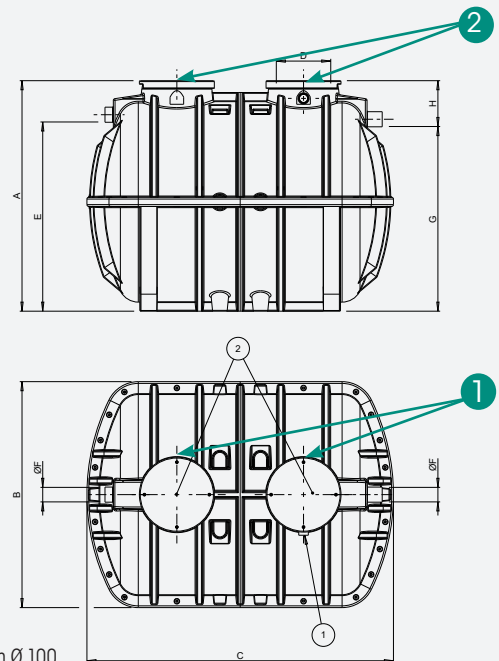

1. Ventilation Ø 100
2. Lid to be put down

5 Installation



Please refer to our website for current documents.

NOTE: Shackles are provided and attached to the tank for handling.

This tank can withstand the presence of groundwater up to its upper generatrix and a maximum of 30 cm of backfill

Reference	Dimensions in mm								Useful volume (m ³)	Max. backfill height (mm)
	A	Ø B	C	Ø D	E	Ø F	G	H		
FTE2/6309/10	2540	2490	3378	600	2085	160	2035	505	10	300
FTE2/6309/12	2540	2490	3928	600	2085	160	2035	505	12	300
RH2/6030	Extension to be placed height 300 mm									
CA3/6394/10T	Anchoring belt to be clicked for installation in the presence of groundwater									

ALL WATER PITS

FROM 10 TO 12 M³
POLYETHYLENE (PE)

6309

6 Earthworks

Make an independent excavation for each tank and if necessary, lower the groundwater table until the backfilling of the device is completed

The walls of the excavation should be about 50 cm all around the tank.

The bottom of the embankment constituting an earthen merlon must be at least 4 m around the tank.

7 Special precautions

After the lateral sand backfill has been completed and the pit has been completely filled, a self-supporting reinforced concrete slab should be built just above the upper generatrix of the tank, resting on the stabilized and undisturbed ground all around the excavation in the following cases :

1. In case of backfill of more than 30 cm above the upper generatrix of the tank.
2. In case of punctual overload due to the passage of vehicles at less than 4 m from the edge of the excavation.
3. When using concrete sockets.
4. In case of overloads due to extreme weather conditions

8 Advice

To reduce the proliferation of mosquitoes in the system, the effluent must not be accessible from the outside, therefore :

- close all lids tightly,
- check and clean the insect screens on the outside air intake caps regularly,
- ensure that the secondary ventilation outlet is equipped with a mosquito screen or odor filter.

POSE EN TERRAIN NON HYDROMORPHE NON ARGILEUX SANS NAPPE PHRÉATIQUE

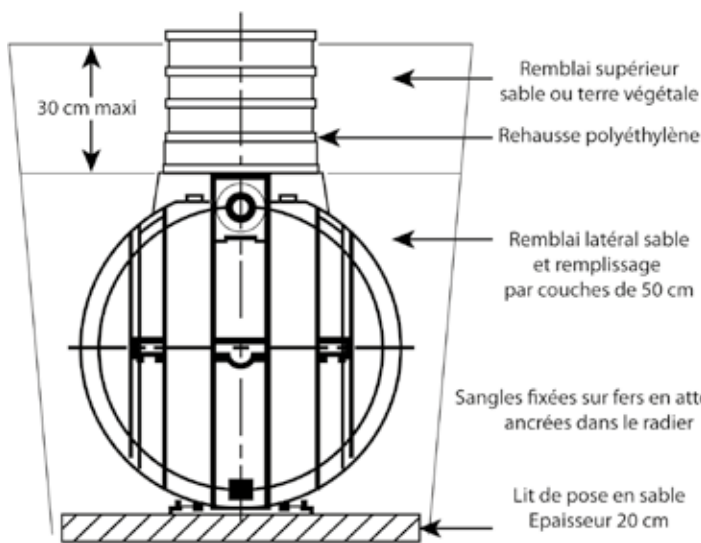

POSE EN TERRAIN HYDROMORPHE ARGILEUX AVEC NAPPE PHRÉATIQUE

