

GREASE SEPARATORS APOLLO RANGE

SILT STORAGE V100 - SIZE 1 TO 7

IN-GROUND INSTALLATION WITH TABLECLOTH OR ABOVE GROUND

MAXIMUM BACKFILL HEIGHT OF 800 MM

POLYETHYLENE (PE)

6630

1 Technical definition

A grease separator is a device designed to separate and store solid matter, fats and oils of animal and vegetable origin contained in household water. A V100 silt storage zone is integrated in each device. Our devices are in accordance with the NF EN 1825-1 standard and are CE marked. The grease retention capacity is 40 liters per l/s.

2 Use

Concerning small communities and professional installations, collective kitchens, restaurants the obligation to install grease separators is based on the standard departmental sanitary regulations and the public health code. **For the food-processing industries** for food industries, it is essential to transmit the CCTP of a technical research department to establish the dimensioning of an adapted device.

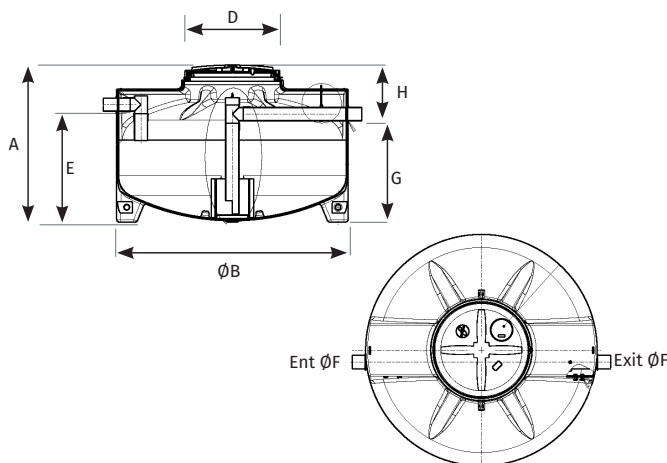

3 Maintenance

The cleaning company must empty the unit regularly, from 15 days to 2 months, depending on the amount of solids and grease collected.

IMPORTANT after each complete draining, wash the unit and fill it immediately with clean water.

4 Installation

Under ground :

The device will be buried and is designed to be installed in the presence of ground water or in hydromorphic soil whose level does not exceed the upper generatrix of the device. If vehicles pass over the device or if the height of the embankment exceeds 800 mm, a reinforced concrete slab must be poured on the undisturbed ground so that the separator is not directly subjected to the loads.

Above ground installation:

The separator must be installed level on a perfectly flat and smooth surface all around the unit. The cover must remain accessible at all times for maintenance purposes. If the unit is installed above ground, it must be equipped with a water collection and drainage system to prevent flooding in the event of overflow. Please refer to our website for current regulations.

5 Remote extraction

Remote extraction in DN80 is possible by ordering the option OD4-BBTN... 1 to 7 (depending on the size). The installer must supply and install a PVC pressure pipe to be connected to the unit outlet and must place the fireman's coupling supplied with the option at the curb.

Reference	Size	A	Ø B	Ø D	E	Ø F	G	H	Volume of sludge trap (l)	Volume Separator (l)	Extraction device option
SG2/6630/01-1	1	832	1244	600	485	100	415	416	103	262	OD4-BBTN1
SG2/6630/02-1	2	1126	1244	600	780	100	710	416	205	509	OD4-BBTN2
SG2/6630/03-1	3	1423	1244	600	1076	100	1006	416	306	756	OD4-BBTN3
SG2/6630/04-1	4	1167	1720	600	825	100	755	412	416	982	OD4-BBTN4
SG2/6630/05-1	5	1397	1720	600	975	160	905	492	526	1228	OD4-BBTN5
SG2/6630/06-1	6	1542	1720	600	1120	160	1050	492	612	1468	OD4-BBTN6
SG2/6630/07-1	7	1702	1720	600	1280	160	1210	492	722	1720	OD4-BBTN7

Options :

- RH2/6031Screw-on extension, can be cut to size, height 300mm
- ANG2-3.....Level alarm for grease traps
- ANG2- 3-N.....Simplified level alarm for grease traps (1 probe possible)
- SNB/SG.....Sludge probe