

## GREASE AND STARCH SEPARATORS SEPARATORS

### V100 SLUDGE TRAP - SIZES 25 TO 80

UNDERGROUND INSTALLATION (WITH OR WITHOUT WATER TABLE)

MAXIMUM BACKFILL HEIGHT OF 500 MM

POLYESTER (PRV)

6633

CE  
EN 1825-1

#### 1 Technical definition

A combined grease and starch separator is a device designed to separate and store solids, fats and oils of animal and vegetable origin contained in household wastewater, and to retain peeling debris. A starch foam spray system is installed above the effluent inlet from the potato peeler. The spray system must be controlled by the peeler. The unit is fitted as standard with a Ø 750 manhole. A V100 silt storage zone is integrated into each unit. Grease retention capacity is 40 liters per l/s.



#### 2 Use

For small communities and professional facilities such as kitchens and restaurants, the obligation to install grease separators is laid down in the standard departmental sanitary regulations and the French Public Health Code.

For food-processing industries, it is essential to send us the specifications of a technical design office to establish the dimensions of a suitable device.

#### 5 Remote extraction

Remote extraction DN80 is possible by ordering option OD3/1924. The installer must supply and install a PVC pressure suction pipe to be connected to the appliance outlet, and must place the fireman's connector supplied with the option at the curb.

#### 3 Installation

Refer to our website to consult the documents in force, in particular the **PHPRV-NC installation instructions**.

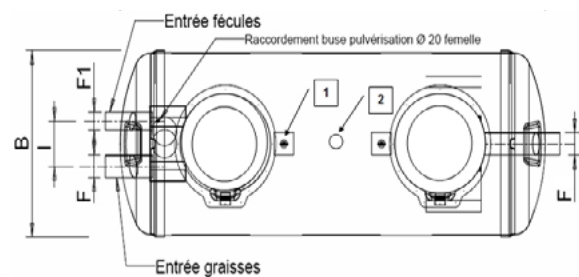
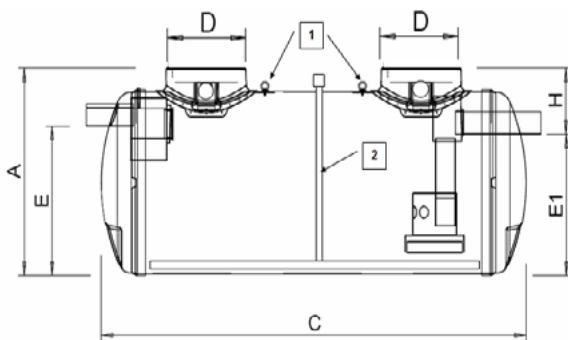

1 - Lifting rings  
2 - DN80 suction option

Reference	Size	A	Ø B	C	D	E	Ø F	G	H	Sludge trap volume (l)	Volume Separator (l)	Number of holes man	Number belts anchor
SG3/6633/16025	25	1832	1642	5612	750	1270	250	1200	632	2530	6049	2	2
SG3/6633/19030	30	2133	1940	4582	750	1570	250	1500	633	3022	7238	2	2
SG3/6633/23045	45	2557	2374	5112	750	1900	315	1830	727	4721	12 014	2	3
SG3/6633/23050	50	2557	2374	5662	750	1900	315	1830	727	5315	13 330	2	3
SG3/6633/23080	80	2557	2374	8912	750	1900	315	1830	727	8826	21 108	2	4

#### Options :

ANG3-4 ..... Grease level alarm  
SNB/SG ..... Sludge probe  
OD3/1924 ..... Remote extraction device DN80  
CA3/6394/10T ..... Click-on anchoring belt for installation in groundwater or hydromorphic soil.