

# HYDROCARBON SEPARATORS 5MG/L WITH V100 SLUDGE TRAP AND BY-PASS POLYETHYLENE (PE)

**6649**

## 1 Technical definition

A hydrocarbon separator is designed to separate and store free hydrocarbons contained in runoff water.

The sludge part of the device traps suspended solids (sand, gravel...). These hydrocarbon separators with bypass and sludge trap are ideal for treating water from parking lots, roads...

Reminder:

A hydrocarbon level alarm is mandatory as additional equipment, unless exempted by local authorities.

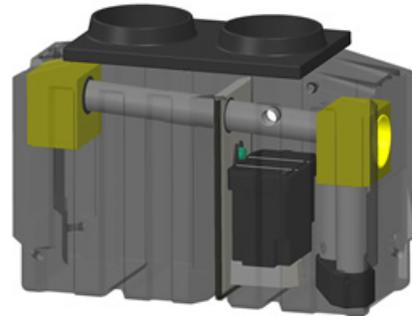

Model with primer(s) of extension(s)

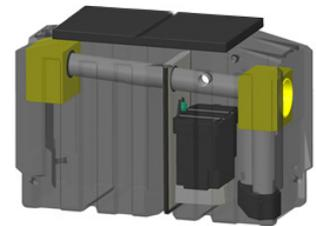

Model with PE pad(s)

## 2 Maintenance

Periodically check that ventilation is not obstructed.

The frequency of emptying must be adapted to the volumes of sludge and hydrocarbons intercepted.

It is recommended to drain the unit when the sludge reaches 50% of the useful volume of the sludge trap or that hydrocarbons reach 80% of the separator's retention capacity (cf. NF P16-442).

Take advantage of draining to clean the coalescence and the shut-off system.

After each draining operation, the unit must be re-connected to the water supply and the obturator checked for leaks.

General E101 maintenance instructions available on our website.

## 4 Operation

The hydrocarbon separator operates by separating non-dissolved pollutants by density difference in run-off water.

The by-pass system located at the level of the inlet box makes it possible to regulate the flow (treatment of 20% of the admissible flow).

The silt storage compartment allows settling and trapping of suspended solids > 200 µm.

Thanks to its large specific surface area, the coalescing system concentrates free hydrocarbons to facilitate their collision. The hydrocarbons then rise to the surface.

The shut-off system prevents any risk of releasing of hydrocarbons.

## 3 Advantages

- design according to NF EN 858-1 and NF EN 858-2
- Tank guaranteed for 20 years against corrosion
- resistance in saline environment
- Resistance in water table or hydromorphic terrain up to outlet water level
- Internal bypass tube
- low weight
- easy to handle
- removable coalescence for easy maintenance
- easy to connect

## 5 Handling - installation

Please refer to the PHPE installation instructions before handling and installing the separator.

- Maximum height of water table = outlet water level.

- Model with PE buffer(s): load-bearing slab mandatory if PE extension + 300mm (note that RH 6069 must be set at minimum). Load-bearing slab mandatory if concrete extension.

- Model with primer(s): concrete load-bearing slab mandatory.

- Max. backfill height= 30 cm above the top shell

# HYDROCARBON SEPARATORS 5MG/L WITH V100 SLUDGE TRAP AND BY-PASS

POLYETHYLENE (PE)

DEVICE WITH PE PAD :

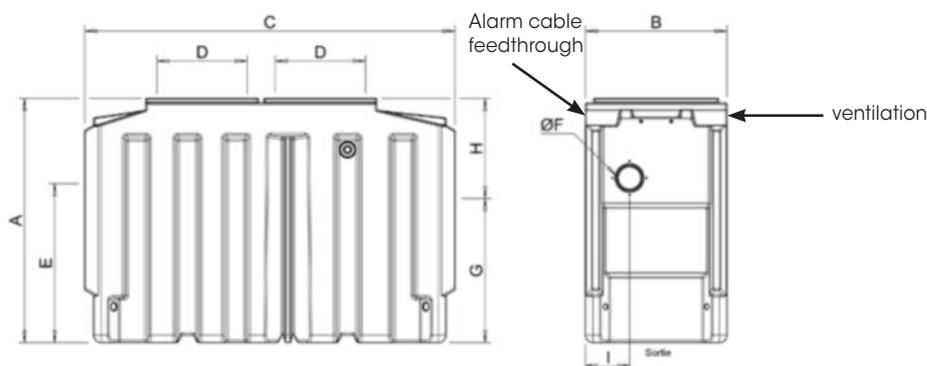

DEVICE WITH PE PRIMER :

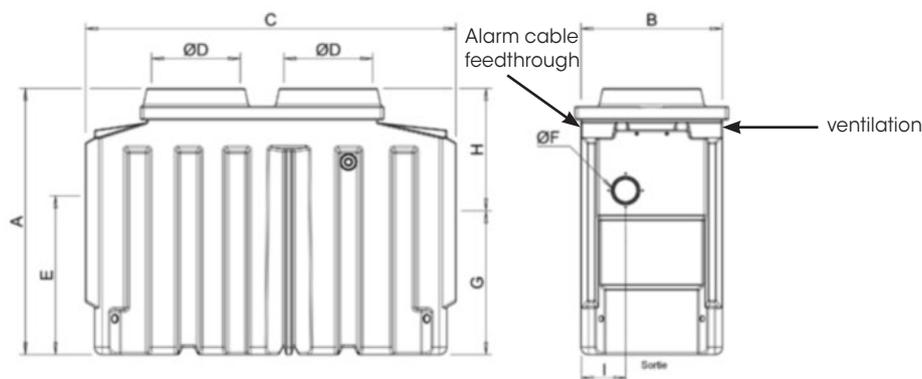

Reference	Treated flow (l/s)	No. of primers	No. of pads	A	B	C	D	E	ØF	G	H	I	Vol. silt storage (litres)	Vol. retention hydrocarbons (liters)	Weight (Kg)
SH2/6649/03	3		1	1280	760	1410	600x690	820	200	720	560	300	300	127	89
SH2/6649/03/00	3	1		1430	760	1410	600	820	200	720	710	300	300	127	95
SH2/6649/06	6		1	1580	850	2000	600x690	1010	250	910	670	326	613	79	148
SH2/6649/06/00	6	1		1730	850	2000	600	1010	250	910	820	326	613	79	153
SH2/6649/08	8		2	1630	940	2220	600x690	1010	315	910	720	335	841	80	209
SH2/6649/08/00	8	2		1780	940	2220	600	1010	315	910	870	335	841	80	218
SH2/6649/10	10		2	1630	940	2460	600x690	1050	315	950	680	340	1030	105	235
SH2/6649/10/00	10	2		1780	940	2460	600	1050	315	950	830	340	1030	105	249
SH2/6649/15	15		2	1900	1540	2400	590x1140	1180	315	1080	820	445	1556	365	336
SH2/6649/15/00	15	2		2050	1540	2400	750	1180	315	1080	970	445	1556	365	350

Options :

- ANH22/14310-N: Visual and sound hydrocarbon alarm with 220V power supply (only 1 hydrocarbon sensor possible) - see FT 4993
- ANH22/14320: Visual and sound hydrocarbon alarm with 220V power supply (3 probes possible) - see FT 4982
- ANH22/14506 : Hydrocarbon alarm with solar panel power supply (connection of up to 6 sensors installed on 2 different separators) - see FT 4981
- OD2/105 : Sludge suction device
- RH6069: Polyethylene extension adjustable from 300 to 450 mm for SH2/6649/03 and SH2/6649/06 units
- RH2/2030: Polyethylene extension adjustable from 200 to 250 mm for separator SH2/6649/15
- CA3/10/3T/2: Set of 2 belts for sizes 1 and 3
- CA3/10/3T/3: Set of 3 belts for size 6
- CA3/6394/10T: 10T-10M anchoring belt + WINCH for separator sizes 8 to 15 (2 required)