

GREASE AND STARCH SEPARATORS SEPARATORS

APOLLO SLUDGE TRAP V100 RANGE - SIZES 1 TO 7

IN-GROUND OR ABOVE-GROUND INSTALLATION

MAXIMUM BACKFILL HEIGHT OF 800 MM

POLYETHYLENE (PE)

6634

GARANTIE
CONTRE LA
CORROSION
JUSQU'À

20 ANS

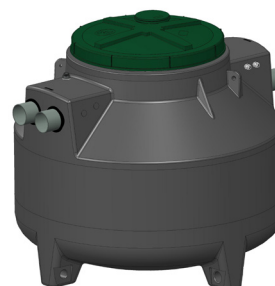

1 Technical definition

A combined grease and starch separator is a device designed to separate and store solid matter, fats and oils of animal and vegetable origin contained in household wastewater, and to retain peeling waste.

A starch foam spray system is installed above the effluent inlet from the potato peeler. The spray system must be controlled by the peeler.

A V100 silt storage zone is integrated in each unit.

Our devices comply with standard NF EN 1825-1 and are CE marked.

Grease retention capacity is 40 liters per l/s.

2 Use

Concerning small communities and professional installations, collective kitchens, restaurants the obligation to install grease separators is based on the standard departmental sanitary regulations and the public health code. **For the food-processing industries** for food industries, it is essential to transmit the CCTP of a technical research department to establish the dimensioning of an adapted device.

3 Installation

The unit is to be installed underground, in the presence of groundwater or in hydromorphic soil whose level does not exceed the upper generatrix of the unit.

Where vehicles pass over the separator, or where the height of the backfill above the separator exceeds 800 mm, a reinforced concrete slab should be poured, supported on the undisturbed ground, so that the separator is not directly subjected to the loads.

This device can also be installed in elevation:

It must be installed level on a perfectly flat and smooth surface all around the unit. The cover must always remain accessible for maintenance.

IMPORTANT please refer to our website to consult the current documents installation instructions P046. For above-ground installation, the room must be equipped with a water collection and drainage system to prevent flooding in the event of overflow

4 Maintenance

The cleaning company must empty the unit regularly, from 15 days to 2 months, depending on the amount of solids and grease collected.

IMPORTANT after each complete draining, wash the unit and fill it immediately with clean water.

5 Remote extraction

Remote extraction in DN80 is possible by ordering **option OD4/BBTN... (1 to 7 depending on size)**. The installer must supply and install a PVC pressure suction pipe to be connected to the unit outlet, and must fit the fireman's fitting supplied with the option at the curb.

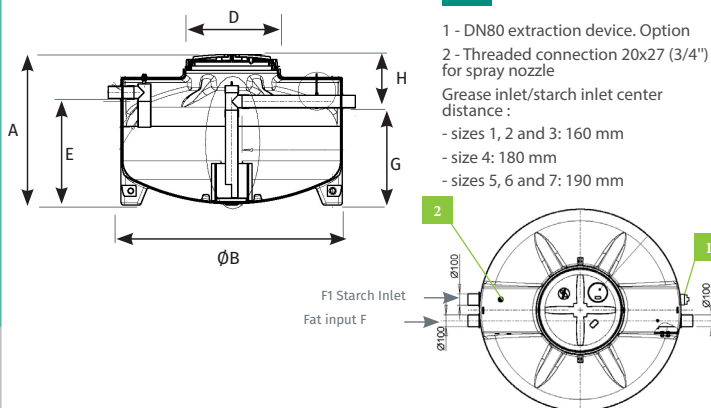

Reference	Size	A	Ø B	Ø D	E	Ø F	Ø F1	G	H	Volume Sludge trap (l)	Volume Separator (l)	Extraction device option
SG2/6634/01-1	1	832	1244	600	485	100	100	415	416	100	260	OD4-BBTN1
SG2/6634/02-1	2	1126	1244	600	780	100	100	710	416	200	505	OD4-BBTN2
SG2/6634/03-1	3	1423	1244	600	1076	100	100	1006	416	300	755	OD4-BBTN3
SG2/6634/04-1	4	1167	1720	600	825	100	100	755	412	400	980	OD4-BBTN4
SG2/6634/05-1	5	1397	1720	600	975	160	100	905	492	500	1225	OD4-BBTN5
SG2/6634/06-1	6	1542	1720	600	1120	160	100	1050	492	600	1468	OD4-BBTN6
SG2/6634/07-1	7	1702	1720	600	1280	160	100	1210	492	700	1720	OD4-BBTN7

Options :

RH2/6031Screw-on extension, can be cut to size, height 300mm
ANG2-3.....Level alarm for grease traps
ANG2- 3-N.....Simplified level alarm for grease traps (1 probe possible)
SNB/SG.....Sludge probe